

The CX 815 and CX 815E Flush Mount 2-Way Coaxial Ceiling Loudspeaker are designed for high ceiling applications in a public address system where directive sound projection is required. The unit consists of a 200 mm 2-way coaxial loudspeaker driver, capable of delivering up to 106 dB of Sound Pressure Level (SPL) and providing excellent speech and music reproduction properties.

The unit's built-in line matching transformer makes it suitable for 70 V and 100 V distributed speaker system. Multiple power tapings on the transformer allows for outputs of 15, 7.5 and 3.8 W (100 V line system) or 7.5, 3.8 and 1.9 W (70 V line system).

The loudspeaker driver unit is mounted onto an aesthetically pleasing 275 mm circular ABS grille finished with a matted surface in Pure White (RAL 9010) and covered with a fine metal mesh. The whole unit is clamp mounted to the ceiling board without any visible screw mounting holes.

The CX 815E features a metal back enclosure which helps eliminate crosstalk within the ceiling cavity, while acoustic damping material lining the enclosure reduces echoing.

- 275 mm circular pure white ABS grille, utilising a 200 mm two way coaxial loudspeaker driver unit, suitable for applications requiring high efficiency and music quality output.
- Clamp mounted installation to eliminate visible mounting screws.
- Ready fitted line matching transformer with multiple impedance tapings, suitable for 70 V and 100 V distributed speaker systems.
- Metal back enclosure (CX 815E) padded with acoustic damping material reduces echoing and enhances speech intelligibility.

**CX 815****CX 815E**

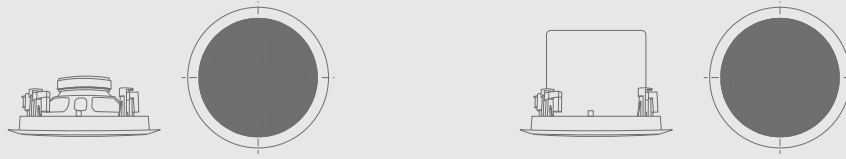

Technical Specifications

	CX 815	CX 815E
Rated Input	100 V : 15 W (15 - 7.5 - 3.8 W) 70 V : 7.5 W (7.5 - 3.8 - 1.9 W)	100 V : 15 W (15 - 7.5 - 3.8 W) 70 V : 7.5 W (7.5 - 3.8 - 1.9 W)
Maximum Power	22.5 W	22.5 W
Rated Impedance	670 Ω (670 - 1330 - 2670 Ω)	670 Ω (670 - 1330 - 2670 Ω)
Sensitivity (1 W / rated at 1m)	94 / 106 dB	94 / 106 dB
Coverage Angle (1 kHz, -6 dB)	120 deg.	120 deg.
Frequency Response	60 Hz ~ 20 kHz	70 Hz ~ 20 kHz
Speaker Component	200 mm 2-Way Coaxial Loudspeaker	200 mm 2-Way Coaxial Loudspeaker
Safety	Acc. to EN 60065	Acc. to EN 60065
Finish	Grille and Mesh; Pure White (RAL 9010)	Grille and Mesh; Pure White (RAL 9010)
Dimensions (W x H x D)	Dia 275 x 95 mm	Dia 275 x 185 mm
Weight	1.9 kg	3.0 kg

Frequency Response

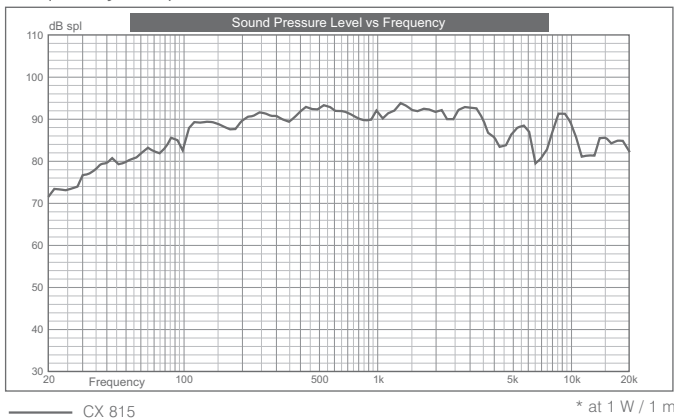

SPL Polar Plot

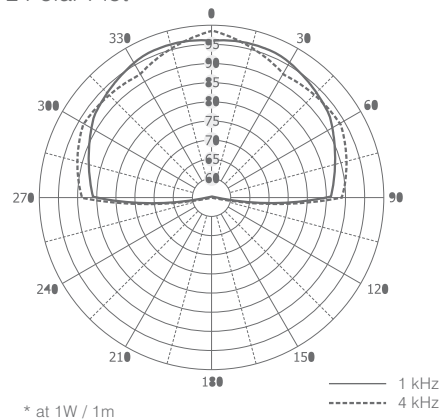

Engineers' Specifications

The coaxial ceiling loudspeaker unit shall consist of a 200 mm 2-way coaxial loudspeaker driver, mounted on to a 275 mm ABS circular grille, finished in pure white and covered with a fine metal mesh. The unit shall be clamp mounted to the ceiling to avoid visible mounting screw. A line matching transformer shall be provided with multiple power tapplings of 15, 7.5 & 3.8 W (100 V) / 7.5, 3.8 & 1.9 W (70 V) suitable for distributed speaker systems. The loudspeaker unit shall have a useable frequency range of 60 Hz ~ 20 kHz (CX 815) / 70 Hz

~ 20 kHz (CX 815E) with a minimum SPL of 94 dB at 1 W / m and a coverage angle of 120 deg.. A metal back enclosure shall be provided as a standard item (CX 815E) and padded with acoustic damping material to reduce echoing. The weight of the unit shall not exceed 1.9 kg (CX 815) / 3.0 kg (CX 815E) and dimensions shall not be more than 275 mm diameter and depth 95 mm (CX 815) / 185 mm (CX 815E).

