

2 INPUT 8 OUTPUT SIGNAL DISTRIBUTION AMPLIFIER | DA2208

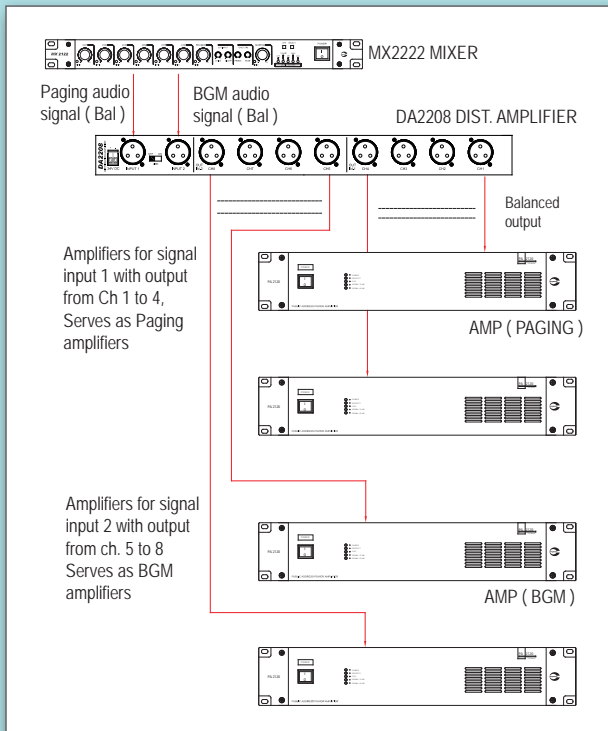

APPLICATION SCHEMATIC :



The above illustration is for Uninterrupted Paging setup. In normal setup with single input, use the link switch to form 1 input 8 outputs configuration. Each output from DA2208 can be linked up to 6 power amplifiers.

Whenever an audio signal from pre-amplifiers are looped to too many amplifier inputs (typically exceeding six), the fidelity of the original waveform would be distorted and sound quality would be compromised. Installing a distribution amplifier shall be able to overcome the problem for a large setup of amplifiers.

DA2208 consists of 2 sets of 1 in 4 out distribution amplifier with option to form 1 in 8 output unit. Each channel shall have its own treble and bass control for better fine tuning the overall installation accordingly to type of speakers used or the acoustic environment of the zone.

FEATURES :

- Operates as dual channel 1 input 4 output or single channel 1 input 8 output
- Individual bass and treble control with volume adjustment
- Direct input signal to output whenever DC power input not available or whenever power failure occurs

TECHNICAL SPECIFICATIONS :

Operating voltage	24V DC
Power consumption	2.4W
Configuration	1 in x 8 out or 2 in x 4 out
Input level	Line : 1V rms max
Input impedance	10 K Ohm
Output gain	+ 4 dB
Output impedance	10 K Ohm
Controls	Bass, Treble, Channel volume
Frequency response	150 ~ 19 KHz (+/- 3 dB at 1 KHz)
Dimensions (WxHxD)	482 x 44 x 180 mm
Weight (kg)	1.55 kg

Rear View

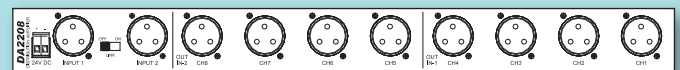

Packing information

Qty per carton : 1 unit
 W x H x D : 552 x 93 x 294 mm
 Weight : 2.15 kg